

TRADITIONAL

 **IMMERGAS**



MINI Range
Combi and heating only
wall-hung compact boilers



MINI NIKE/EOLO

Combi and heating only wall-hung compact boilers, open chamber, room-sealed

COMPACT SHAPED TECHNOLOGY

Technology, among other things, means making everything simple and comfortable: this is how the **new MINI boiler range** was born, thought to facilitate the installation and maintenance operations at the most and fully satisfy any sanitary hot water exigency.

A modern design studied to suit any furnishing demand, compact dimensions and innovative technology, make the MINI range the ideal solution both in case of new installation and existent system substitution.

The range consists of five new models, both room-sealed fan assisted and

open chamber conventional flue. Additionally, both versions feature room heating only models. The heat outputs go from 24 to 28 kW.

INTELLIGENT CONTROL SYSTEM

All new MINI boilers are equipped with a backlit display informing the user about the boiler functioning with clear indications for an easy and immediate use of the appliance. Besides, the auto diagnostic system with related code visualization further facilitates the technician's work in case of necessity. The new MINI range presents another important feature: the possibility to be combined with Immergas climatic

thermoregulation wide range and the integration with the solar function in case of combination with Immergas Solar Solutions.

SPACE SAVING RANGE

Thanks to reduced dimensions, the MINI range appears really compact: ideal to be installed in niches or in limited space rooms!

To further simplify the installation operations, in case of substitution with a previous version, the new MINI range connection disposition and size remain unchanged thus eliminating any brick works.





MINI NIKE/EOLO

COMPACT DIMENSIONS

PERFECT TEMPERATURE CONTROL

HIGH RELIABILITY
COPPER EXCHANGER

USER-FRIENDLY
CONTROL BOARD

COMBINABLE
WITH SOLAR SYSTEMS

SERVICE BEYOND THE PRODUCTS

Immergas believes in customer service as a strategy to gaining the trust of their target, ensuring a high level of satisfaction and winning over new markets.

The massive worldwide presence of a technical service network is a crown jewel of Immergas Service, to ensure qualified support for any after-sales service need.



COMFORT IS COMPACT

Modern and harmonic, the new MINI boiler design perfectly integrates in any living space, while the particularly compact dimensions (24 cm depth only for the 24 kW models) allow for the installation inside a wall cabinet. The reduced weight allows the installer to easily move and mount the boiler, therefore saving money and time.



.01 ADVANCED ELECTRONICS

The new MINI boilers are combinable with Immergas remote control system range allowing remotely regulating and using the appliance. In addition, the external probe kit allows increasing the thermal system energetic efficiency, at the same time reducing gas consumptions. The electronic board features an innovative solar function, to manage the boiler cold water inlet with a thermal solar system.

.01



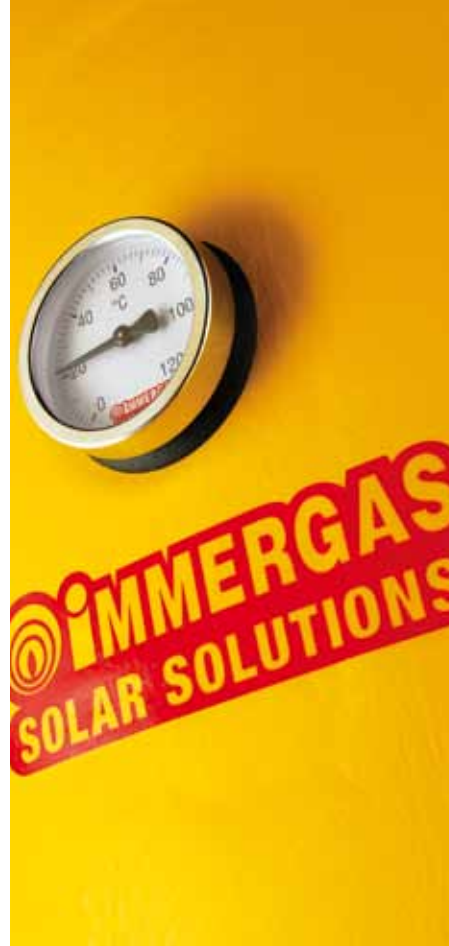

.02

STORAGE TANK COMBINABLE

Lots of hot water for small and big spaces. In case of great hot water exigencies, the MINI X versions (heating only) can be combined with a separate storage tank, using a proper optional connection kit. This feature allows combining the boiler to Immergas Solar Solutions.

IDEAL FOR OUTDOOR INSTALLATION

Prearranged to be installed outdoor, to solve dimension problems and enlarge domestic space, EOLO versions are homologated to function in partially protected spaces (e.g. under a balcony) with a standard protection up to -5 °C, or up to -15 °C using an anti-freeze protection kit (as option).

.02 NEW THERMOREGULATION

MINI EOLO is combinable with the new CAR^{V2} (*) and CAR Universal, both modulating room thermostats to remotely control the boiler.

Common functions:

- Weekly setting on 2 room temperature levels (comfort - reduced)
- Easy and intuitive controls
- Possible errors visualization
- 9 fixed climatic curves regulation (if connected to the external probe)
- Anti-freeze function

CAR^{V2} (*) specific functions:

- New aesthetic
- Holiday function
- Building thermal inertia setting
- Climatic curve auto adapting function
- Anti-freeze function from 0 to 10 °C

(*) Ask for product availability before placing your order.



MINI NIKE/EOLO

Combi and heating only wall-hung compact boilers, open chamber, room-sealed



GENERAL CHARACTERISTICS

- ↘ Available heat outputs of 24 and 28 kW
- ↘ NIKE: open chamber, combi and heating only (X version)
- ↘ EOLO: room-sealed, combi and heating only (X version)
- ↘ Compact dimensions
- ↘ Boiler diagnostic by display
- ↘ Double NTC probe for the temperature check
- ↘ Copper primary exchanger and stainless steel plates secondary exchanger
- ↘ Combinable with external probe
- ↘ Adjustable by-pass
- ↘ Combinable with Immergas solar systems
- ↘ Optional hydraulic connection kit

EOLO Technical data	Unit of measurement	MINI EOLO 24 3 E	MINI EOLO 28 3 E	MINI EOLO X 24 3 E
Code	N.G. L.P.G.	3.020853 3.020853GPL	3.020856 3.020856 GPL	3.020855 3.020855GPL
CE certificate		0694BU2141	0694BU2141	0694BU2141
Maximum nominal heat input	kW	25,6	29,7	25,6
Maximum useful heat output	kW	24,0	28,0	24,0
Minimum heat input D.H.W.	kW	8,3	9,6	--
Minimum heat input heating	kW	10,5	12,5	10,5
Minimum useful heat output D.H.W.	kW	7,2	8,5	--
Minimum useful heat output heating	kW	9,3	11,2	9,3
Efficiency at 100% nominal heat output	%	93,6	94,3	93,6
Efficiency at 30% nominal heat output load	%	90,3	91,1	90,3
Gas flow rate burner ON (with N.G.) max/min	m ³ /h	2,71/0,88	3,14/1,02	2,71/0,88
Flow rate for continuous service (Δt 30 °C)	l/min	11,5	13,4	--
Central heating expansion vessel capacity	litres	6	8	6
Protection index	IP	X5D	X5D	X5D
Full appliance weight (empty)	Kg	34,5 (32)	40,8 (38)	33,9 (31,4)

NIKE Technical data	Unit of measurement	MINI NIKE 24 3 E	MINI NIKE X 24 3 E
Code	N.G. L.P.G.	3.020852 3.020852 GPL	3.020857 3.020857GPL
CE certificate		0694BU2141	0694BU2141
Maximum nominal heat input	kW	26,2	26,2
Maximum useful heat output	kW	23,8	23,8
Minimum heat input D.H.W.	kW	8,3	--
Minimum heat input heating	kW	10,9	10,9
Minimum useful heat output D.H.W.	kW	7,0	--
Minimum useful heat output heating	kW	9,4	9,4
Efficiency at 100% nominal heat output	%	91,0	91,0
Efficiency at 30% nominal heat output load	%	89,3	89,3
Gas flow rate burner ON (with N.G.) max/min	m ³ /h	2,77/0,88	2,77/0,88
Flow rate for continuous service (Δt 30 °C)	l/min	11,4	--
Central heating expansion vessel capacity	litres	6	6
Protection index	IP	X4D	X4D
Full appliance weight (empty)	Kg	28,6 (26,1)	28 (25,5)

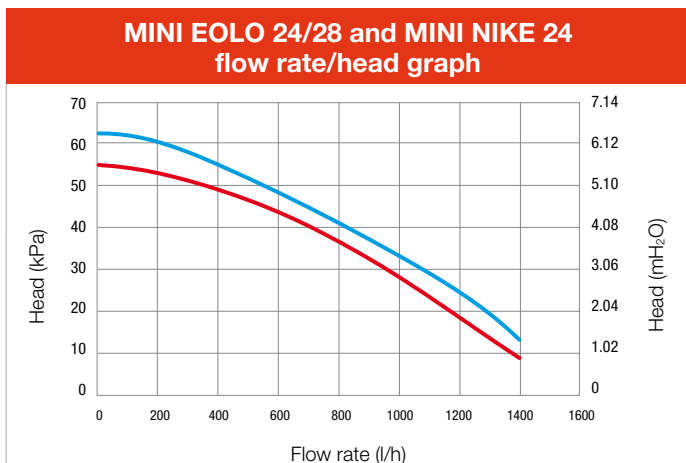

Available head in the system:

- at top speed with excluded by-pass 24 kW
- at top speed with excluded by-pass 28 kW



MINI EOLO

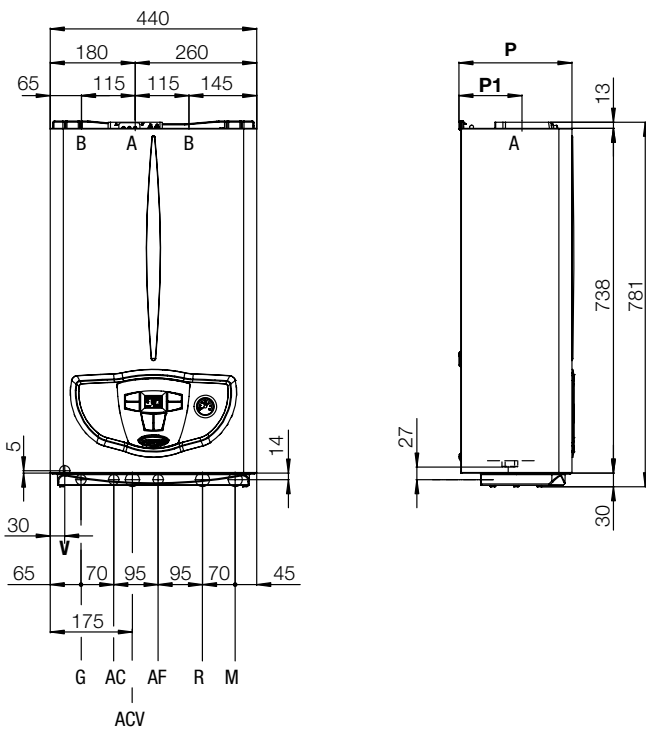

P = 240 mm (EOLO 24) **P1** = 135 mm (EOLO 24)
P = 340 mm (EOLO 28) **P1** = 195 mm (EOLO 28)

MINI EOLO 24/28 and MINI NIKE 24 hydraulic connections (optional)

Gas	D.H.W.		System	
	AC	AF	R	M
3/4"*	1/2"	1/2"	3/4"	3/4"

(* The boiler is equipped with a 90° gas cock with 3/4" connections and Ø 18 mm to be welded fitting. N.B.: the gas cock must come out 200 mm at least from the connections horizontal wall.

Key

- G** Gas supply
- AC** Domestic hot water outlet
- ACV** Solar valve domestic hot water inlet (option)
- AF** Domestic cold water inlet
- R** System return
- M** System delivery
- V** Electrical connection
- A** Inlet/outlet
- B** Inlet

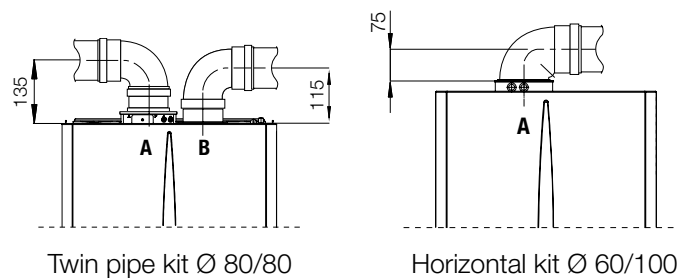

During the life of a boiler, performance is influenced by external factors, e.g. water hardness, atmospheric agents, system limiting, etc. The published data refers to new products correctly installed and used, in accordance with local regulations. N.B. We recommend regular periodic maintenance of the appliance.



Immergas S.p.A. - 42041 Brescello (RE) Italy
 T. +39.0522.689011 - F. +39.0522.689178
 www.immergas.com



IMMERGAS SPA - ITALY
 CERTIFIED COMPANY
 UNI EN ISO 9001:2000

Design, manufacture and post-sale assistance of gas boilers, gas water heaters and related accessories